

SOLUBO.





As formas de trabalho mudaram, os escritórios deixaram de ser um aglomerado de mesas, cadeiras e armários. A tecnologia e a sociedade revolucionaram a forma como os espaços de trabalho são concebidos e projetados. Eliminaram-se gradualmente os elementos de divisão, gabinetes, espaços de armazenamento... as mesas acolhem hoje múltiplas funções. Esta reconfiguração, aliada à tecnologia promoveu a flexibilidade dos horários e provocou a interligação das diversas ações do Homem no seu quotidiano... trabalhar, comer, conversar, não são hoje ações isoladas. PONTE adapta-se à diversidade de usos e funções atuais, assume-se como uma ferramenta operativa de design unificado e flexível.

Las formas de trabajo han cambiado, las oficinas ya no son un conjunto de escritorios, sillas y armarios archivadores. La tecnología y la sociedad han revolucionado el modo en que se diseñan y se conciben los espacios de trabajo. Se han eliminado elementos divisorios, despachos y poco a poco los espacios de almacenaje... las mesas de trabajo son multifuncionales. Esta reconfiguración, aliada a la tecnología promocionó la flexibilidad de la jornada laboral y se introduce en el cotidiano del trabajador... trabajar, comer, charlar, no son actos separados. PONTE se adapta a la diversidad de usos y funciones actuales, se asume como una herramienta operativa de diseño unificado y flexible.

Work environments have changed. An office is no longer a room with a bunch of tables, chairs and cabinets. Technology and society have revolutionised the way workspaces are planned and designed. Dividing elements, cabinets and storage spaces have been gradually eliminated... the tables now accommodate multiple functions. This new layout combined with new technologies, promoted schedule flexibility and led to the intertwining of our various daily life activities. Working, eating and talking with each other are no longer isolated actions. The PONTE adapts to the current diversity of uses and functions, standing as an operative tool with an integrated and flexible design.

Les formes de travail ont changé, les bureaux ont cessé d'être un ensemble de tables, de chaises et de placards. La technologie et la société ont révolutionné la conception des espaces de travail. Les cloisons, les armoires, les espaces de rangement ont graduellement disparu... les tables hébergent maintenant plusieurs fonctions. Cette reconfiguration, alliée à la technologie, a favorisé la flexibilité des horaires et a permis l'interconnexion des diverses actions de l'Homme dans sa vie quotidienne ... travailler, manger, parler ne sont pas des actions isolées aujourd'hui. PONTE s'adapte à la diversité des utilisations et des fonctions actuelles, il s'impose comme un outil de design flexible.



"DIA DE TRABAJO"





"TOMAR UM CAFÉ"



**DESCONTRAIR**  
RELAX/RELAXING/SE DÉTENDRE

O pequeno-almoço no local de trabalho, conviver com os colegas, verificar o e-mail ou estudar a agenda do dia. Adaptável a todos os ambientes.

El desayuno en la oficina, convivir con los compañeros de la empresa, comprobar el e-mail o la agenda del día. Adaptable a todos los ambientes.

Having breakfast at work, hanging out with your workmates, checking your email or your daily planner. Adapts to any environment.

Petit-déjeuner sur place, bavarder avec les collègues, vérifier les e-mails ou étudier l'agenda du jour. Adaptable à tous les environnements.

\*TOMAR UM CAFÉ  
HAVE A CUP OF COFFEE  
PRENDRE UN CAFÉ



"REUNIÕES"



**INFORMAL**  
INFORMAL / INFORMAL / INFORMEL

Reuniões no âmbito laboral ou familiar.  
As pernas recuadas permitem utilizar  
os topos com comodidade.

Reuniones en el ámbito laboral o  
familiar. Las patas remetidas permiten  
utilizar las cabeceras con comodidad.

Work or family meetings. The recessed  
legs allow you to use the top with full  
comfort.

Réunions au travail ou en famille.  
Les pieds en retrait vous permettent  
d'utiliser les hauts de manière  
confortable.

\*REUNIONES  
MEETINGS  
RÉUNIONS



“EXPERIÊNCIAS PESSOAIS E SOCIAIS”



**LAZER**  
OCIO/RECREATION/LOISIR

Descontrair, procurar inspiração ou reforçar o espírito social.

Desconectar, buscar inspiración o reforzar el espíritu social.

Relaxing, looking for inspiration or strengthening social ties.

Détendez-vous, recherchez l'inspiration ou renforcez l'esprit social.

\*EXPERIENCIAS PERSONALES Y SOCIALES  
PERSONAL AND SOCIAL EXPERIENCES  
EXPERIENCES PERSONNELLES ET SOCIALES



"APRESENTAÇÕES"



**TRABALHO**  
TRABAJO / WORK / TRAVAIL

Conceitos, estratégias, branding e conferências.

Conceptos, estrategias, branding y conferencias.

Concepts, strategies, branding and conferences.

Concepts, stratégies, stratégie de marque et conférences.

\*PRESENTACIONES  
PRESENTATIONS  
PRÉSENTATIONS



“NO ESCRITÓRIO OU SALA DE JANTAR”



**REFEIÇÃO**  
PARA COMER/MEAL/LE REPAS

Chegou a hora de almoçar após uma longa reunião.

Llegó la hora de comer después de una larga reunión.

It's time for lunch, after a long meeting.

Il est temps de déjeuner après une longue réunion.

\* EN LA OFICINA O EN EL COMEDOR  
IN THE OFFICE OR IN THE DINING ROOM  
AU BUREAU OU DANS LA SALLE À MANGER





“COLABORAÇÕES LABORAIS”



SOLUDO.

HOLA arquitetura

**ESTUDO**  
ESTUDIO/STUDY/L'ÉTUDE

Debate de ideias para obter o melhor resultado.

Debate de ideas para obtener el mejor resultado.

Brainstorming to reach the best results.

Un brainstorming pour obtenir le meilleur résultat.

\*COLABORACIONES LABORALES  
COLLABORATIVE WORK  
TRAVAIL COLLABORATIF



"FUNCIONALIDADE DOS ESPAÇOS"



**MODULAR**  
MODULAR/MODULAR/MODULER

Adapta-se a todos os espaços e funções.

Se adapta a todos los espacios y funciones.

Adapts to all spaces and functions.

S'adapte à tous les espaces et fonctions.

\*FUNCIONALIDAD DE LOS ESPACIOS  
SPACE FUNCTIONALITY  
FUNCTIONNALITÉ DES ESPACES



*“MÚLTIPLAS DIMENSÕES PARA RESPONDER AOS  
DIFERENTES ESPAÇOS”*





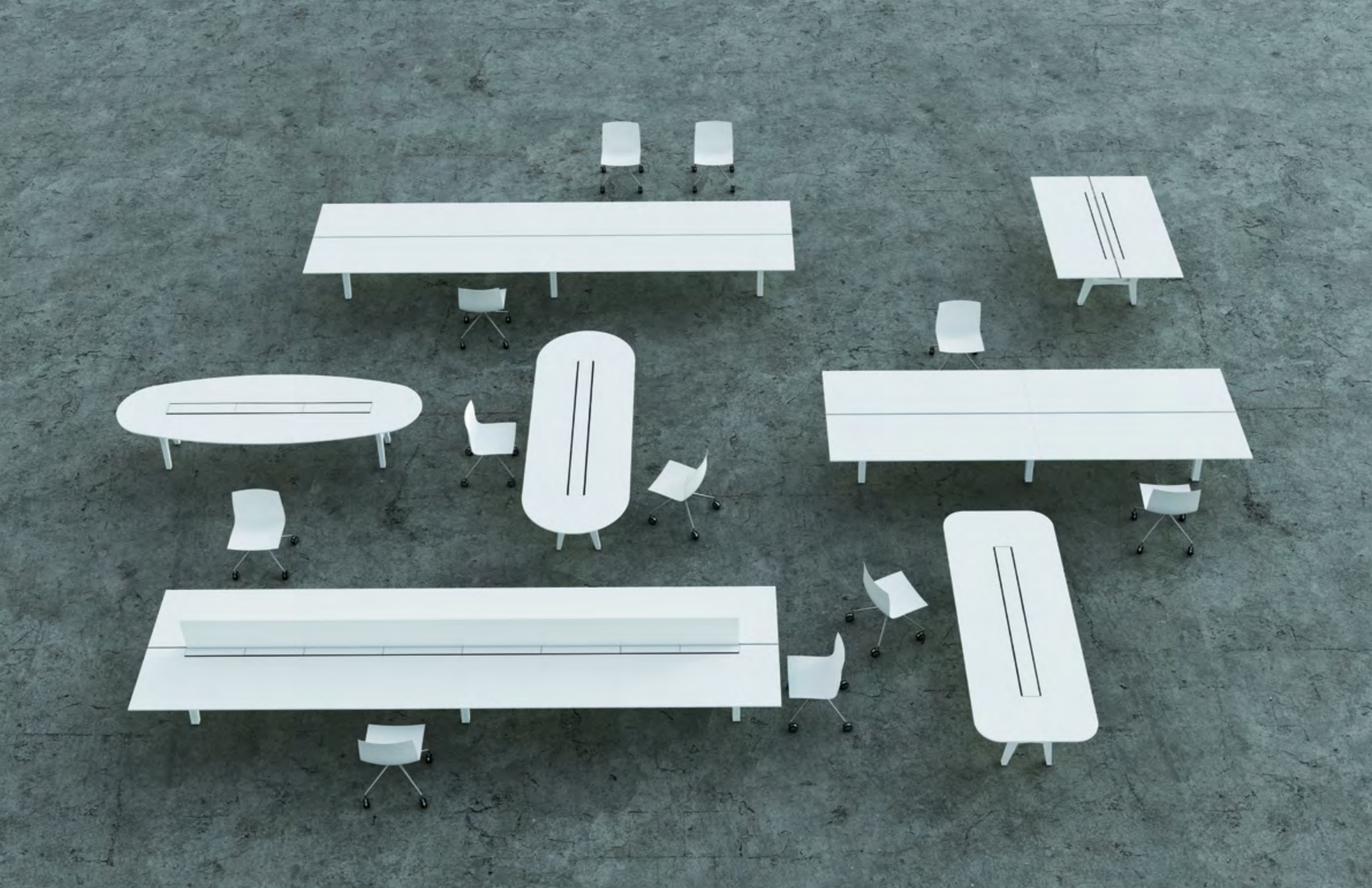





80



120



162

## TAMPOS

ENCIMERAS / TOP / TABLEAU

Executados em aglomerado de madeira de 19mm, com revestimento melamínico nas duas faces e orla perimetral em PVC com perfil recto. Os diferentes acabamentos melamínicos (Branco, Carvalho Trigo, Nogueira e Preto) permitem explorar múltiplas conjugações sensoriais e espaciais, adaptáveis a todos os conceitos estéticos e culturais.

Made of 19-mm wood chipboard, with melamine coating on both sides and straight-profile PVC edge banding. The different melamine finishes (White, Oak, Wheat, Walnut and Black) allow exploring multiple sensorial and spatial conjugations, and can adapt to any aesthetic and cultural design.

Encimeras ejecutadas en aglomerado de madera de 19 mm, con revestimiento melamínico por las 2 caras y canto perimetral en PVC de perfil recto. Los diferentes acabados melamínicos (Blanco, Roble Trigo, Nogal y Negro) permiten explotar múltiples soluciones sensoriales y espaciales, adaptables a todos los conceptos estéticos y culturales.

Réalisé en bois aggloméré de 19 mm, mélaminé des deux côtés et bord périmétrique en PVC à profil droit. Les différentes finitions en mélamine (Blanc, Chêne Blé, Noyer et noir) permettent d'explorer de multiples conjugaisons sensorielles et spatiales, adaptable à tous les concepts esthétiques et culturels.

## PERNAS

PATAS / LEGS / PIEDS

O elemento chave da PONTE são as pernas que permitem a multiplicação de postos com reduzidos elementos estruturais. Executadas em aço com acabamentos em pintura Epoxy em Castanho Siena, Preto Texturado, Amarelo e RAL9003 (Texturado ou Liso). Recuadas relativamente ao tampo, assumem-se como protagonistas deste produto conferindo múltiplas opções funcionais.

The key element of the PONTE table are its legs, which allow multiplying workstations with minimal structural elements. Made of steel with Epoxy paint finish in various colours: Siena Brown, Textured Black, Yellow and RAL9003 (textured or glossy) recessed in relation to the top, they take on a central role in this product, as they allow for multiple functional options.

El elemento clave de la PONTE son las patas que permiten la multiplicación de los puestos con reducidos elementos estructurales. Ejecutadas en acero con acabados en pintura Epoxy en Marrón Siena, Negro Texturizado, Amarillo y RAL 9003 (texturizado y liso). Remetidas con respecto a la encimera, son las protagonistas de este producto aportando múltiples opciones funcionales.

L'élément clé du PONTE est les pieds qui permettent la multiplication de postes de travail avec des éléments structurels réduits. Fabriqué en acier avec des finitions de peinture Epoxy en Brun Siena, Noir Texturé, Jaune et RAL9003 (texturé ou lisse). Rétractés relativement du plateau, ils jouent le rôle de plusieurs options fonctionnelles.



**SECRETÁRIA INDIVIDUAL**

SECRETARIA INDIVIDUAL  
INDIVIDUAL DESK  
SECRETAIRE INDIVIDUEL

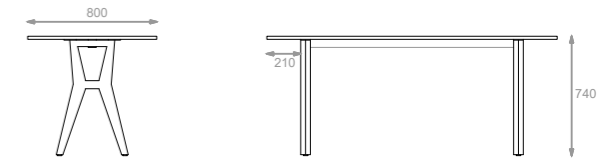

**MESA DE REUNIÃO**

MESA DE REUNIÓN  
CONFERENCE TABLE  
TABLE DE LA REUNION

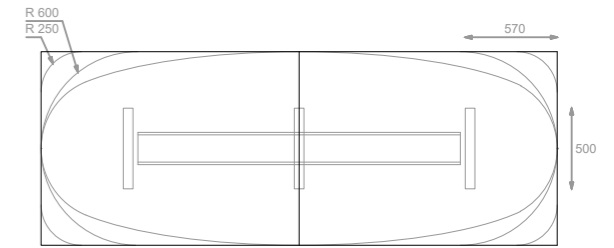
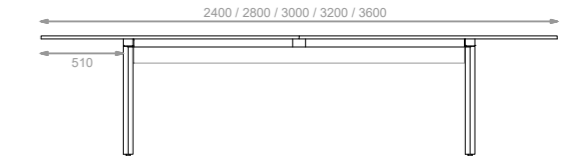
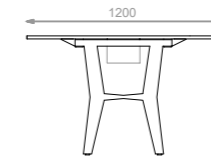
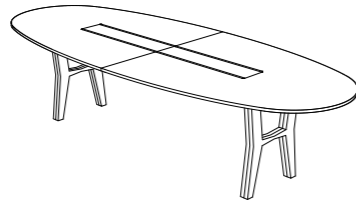

**SECRETÁRIA DUPLA**

SECRETARIA DOBLE  
DOUBLE DESK  
DOUBLE SECRÉTAIRE

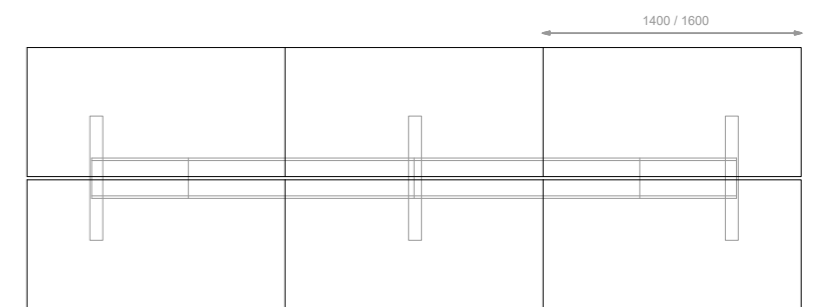
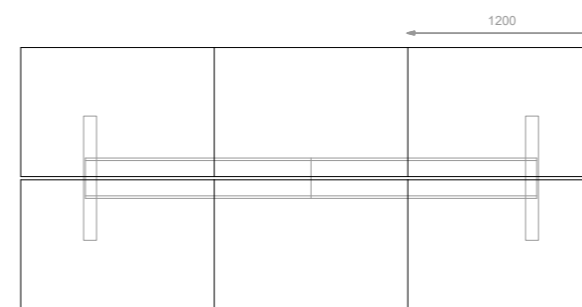
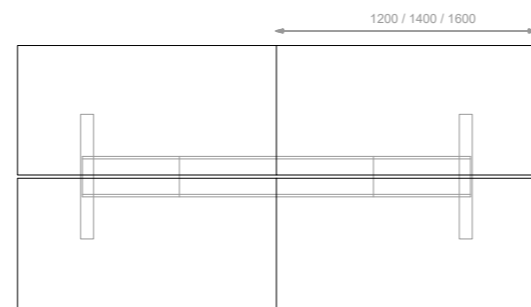
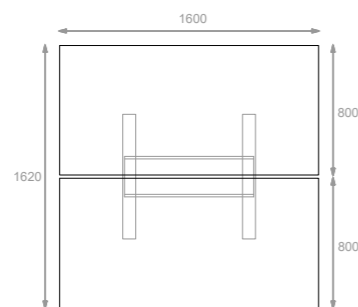
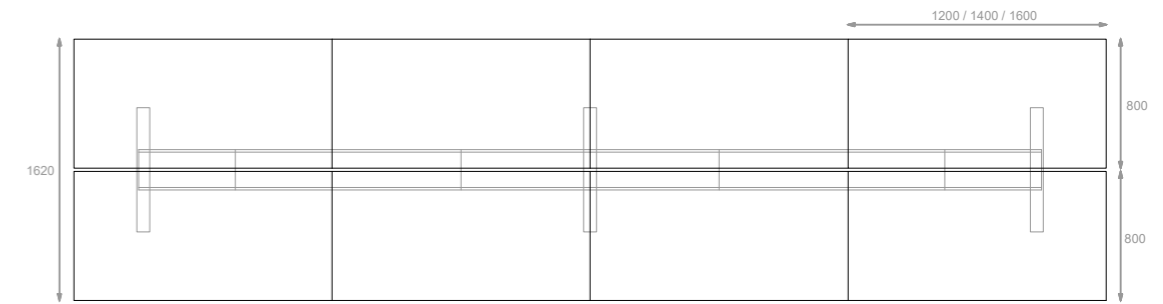
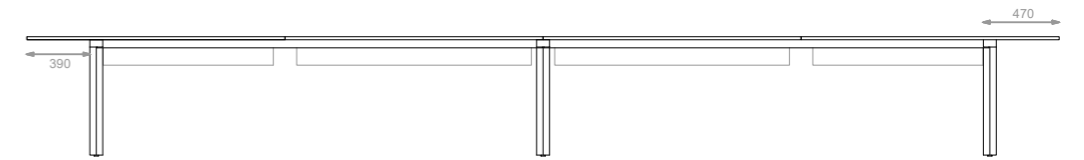
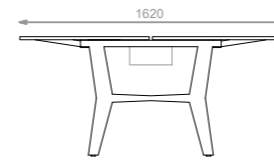
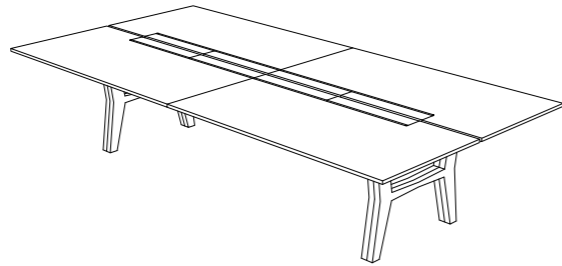



SOTUBO - MÓVEIS METÁLICOS, S.A.

sotubo@sotubo.pt

SOTUBO.pt



COFINANCIADO POR  
**COMPETE**  
2020





